



**BELLINGER**  
SYSTEMS  
A SYPAQ Company

## Link Level COMSEC (LLC) Quick Release Mounting Tray LMT-1

TOOL FREE INSTALLATION AND DEINSTALLATION OF LLC UNITS

### HIGHLIGHTS

Facilitates sub 2-minute declassification times, no tools required.

Removes the need for rear cable access and cable management.

Increased mechanical stability over a flat tray design.

Removes need to undo any connectors, minimises wear and damage.

Protects LLC unit when out of rack, while in transit and while stowed when declassified.



**Bellinger Systems delivers quality, user focused solutions to all installation design challenges wherever mission critical operations require bespoke solutions.**

Designed for use on any platform or facility, the LLC Quick Release Mounting Tray LMT-1 allows rapid installation, deinstallation and declassification of the system in under 2 minutes, with no tools or rear access required.

A slide-in enclosure mounts to a rack fixed base with connections made through MIL-SPEC connectors to the fixed case. For ease of retrofit, the fixed case uses the conventional LLC connections on the rear that will already be present in racks if the LLC units were previously installed.

The fixed and slide-in tray sections are not uniquely matched, allowing for swapping of the LLC units with no additional rework required.

Red and black separation of data is maintained in separate shielded enclosures in both the fixed and removable tray sections of the LMT-1 for added isolation.

Due to the use of push fit MIL-SPEC connectors, wear and damage to the ship's cable side connectors is minimized. They are connected once when the fixed tray is installed, then left undisturbed. This also simplifies cable management behind the units as the ships cable does not need to extend and retract when removing the LLC units.

This arrangement has significant advantages over a flat tray design such as quick, tool free removal and installation of the LLC units as well as installation when there is no rear rack access.



FS 605111

[www.bellinger.com.au](http://www.bellinger.com.au)



# BELLINGER

## SYSTEMS

A SYPAQ Company

### CONTACT DETAILS

**Email**  
sales@bellinger.com.au

**Phone**  
+61 2 9684 1424

**Address**  
4-6 Muriel Avenue  
Rydalmere NSW  
Australia 2116

**Mail**  
PO Box 149  
Ermington NSW  
Australia 1700



FS 605111

[www.bellinger.com.au](http://www.bellinger.com.au)

## LMT-1

### IN EXTENDED POSITION

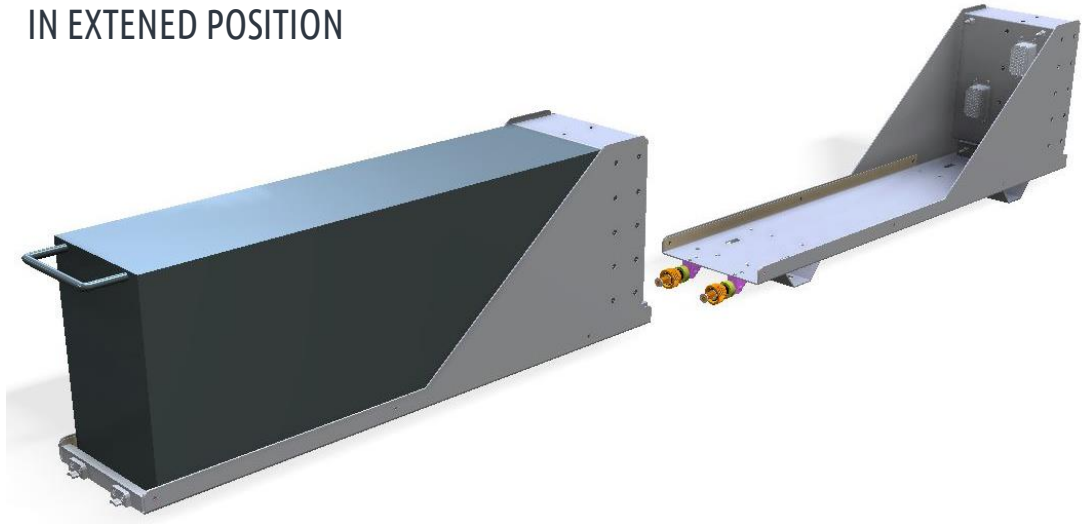

**MODEL NO.** LMT-1  
**PART NO.** 101041-005-AS-0051

### SERVICES AVAILABLE

Technical Support  
Installation and Setup  
Maintenance  
Application Support  
Hardware Support  
Guaranteed Warranty

### SPECIFICATIONS

#### ENVIRONMENTAL

Designed to meet

Vibration	MIL-STD-810G method 514.6 (various) MIL-STD 167-1A type 1
Shock (Transit Drop)	MIL-STD-810G method 516.6 (various) MIL-STD 901D grade A
Operating Temperature	-40°C to +80°C
Storage Temperature	-40°C to +85°C

#### PHYSICAL

Weight (incl. LLC)	17kg
Weight (no LLC)	8Kg
Height	225.5mm
Width	140.5mm
Length	705mm

